

*The Embedded I/O Company*



---

# TIP700

## Digital Output 24V DC

Version 1.1

### User Manual

Issue 1.1.5

March 2009

D757700801

---

**TEWS TECHNOLOGIES GmbH**

Am Bahnhof 7  
25469 Halstenbek, Germany  
[www.tews.com](http://www.tews.com)

Phone: +49-(0)4101-4058-0  
Fax: +49-(0)4101-4058-19  
e-mail: [info@tews.com](mailto:info@tews.com)

**TEWS TECHNOLOGIES LLC**

9190 Double Diamond Parkway,  
Suite 127, Reno, NV 89521, USA  
[www.tews.com](http://www.tews.com)

Phone: +1 (775) 850 5830  
Fax: +1 (775) 201 0347  
e-mail: [usasales@tews.com](mailto:usasales@tews.com)

**TIP700-10**

16 isolated digital outputs 24V DC

**TIP700-20**

8 isolated digital outputs 24V DC

This document contains information, which is proprietary to TEWS TECHNOLOGIES GmbH. Any reproduction without written permission is forbidden.

TEWS TECHNOLOGIES GmbH has made any effort to ensure that this manual is accurate and complete. However TEWS TECHNOLOGIES GmbH reserves the right to change the product described in this document at any time without notice.

TEWS TECHNOLOGIES GmbH is not liable for any damage arising out of the application or use of the device described herein.

**Style Conventions**

Hexadecimal characters are specified with prefix 0x, i.e. 0x029E (that means hexadecimal value 029E).

For signals on hardware products, an 'Active Low' is represented by the signal name with # following, i.e. IP\_RESET#.

Access terms are described as:

W	Write Only
R	Read Only
R/W	Read/Write
R/C	Read/Clear
R/S	Read/Set

©1994-2009 by TEWS TECHNOLOGIES GmbH

All trademarks mentioned are property of their respective owners.

---

<b>Issue</b>	<b>Description</b>	<b>Date</b>
1.0	First Issue	June 1994
1.1	Technical Specification	April 1996
1.2	Schematics	May 1997
1.3	General Revision	October 2002
1.4	Revision MTBF value	September 2006
1.1.5	New notation of User Manual Issue	March 2009

# Table of Contents

<b>1</b>	<b>PRODUCT DESCRIPTION</b> .....	<b>6</b>
<b>2</b>	<b>TECHNICAL SPECIFICATION</b> .....	<b>7</b>
<b>3</b>	<b>ID PROM CONTENTS</b> .....	<b>8</b>
<b>4</b>	<b>IP ADDRESSING</b> .....	<b>9</b>
<b>5</b>	<b>FUNCTIONAL DESCRIPTION</b> .....	<b>10</b>
	<b>5.1 Digital Outputs</b> .....	<b>10</b>
	5.1.1 Optical Isolation .....	10
	5.1.2 Output Polarity .....	10
	5.1.3 Overload Protection .....	10
	5.1.4 Output Watchdog.....	10
<b>6</b>	<b>PROGRAMMING</b> .....	<b>11</b>
	<b>6.1 Output Data Register OUTDAT (Base Address +0x00)</b> .....	<b>11</b>
	<b>6.2 Watch Dog Control Register (Base Address 0x02)</b> .....	<b>12</b>
<b>7</b>	<b>INSTALLATION</b> .....	<b>13</b>
<b>8</b>	<b>IP I/O CONNECTOR</b> .....	<b>14</b>

---

## List of Figures

FIGURE 1-1 : BLOCK DIAGRAM.....	6
FIGURE 7-1 : OUTPUT WIRING AS HIGH SIDE SWITCH.....	13
FIGURE 7-2 : OUTPUT WIRING AS LOW SIDE SWITCH.....	13

## List of Tables

TABLE 2-1 : TECHNICAL SPECIFICATION.....	7
TABLE 3-1 : ID PROM CONTENTS TIP700-10.....	8
TABLE 3-2 : ID PROM CONTENTS TIP700-20.....	8
TABLE 4-1 : REGISTER MAP.....	9
TABLE 6-1 : OUTPUT DATA REGISTER OUTDAT .....	11
TABLE 6-2 : WATCH DOG CONTROL REGISTER WDGCSR.....	12
TABLE 8-1 : OUTPUT I/O CONNECTION OUTPUT 1 TO 8.....	14
TABLE 8-2 : OUTPUT I/O CONNECTION OUTPUT 9 TO 16 (TIP700-10 ONLY).....	15

# 1 Product Description

The TIP700 is an IndustryPack® compatible module with digital outputs interfacing directly to 24 volt DC control voltage. There are two versions available: The TIP700-10 implements 16 outputs, the TIP700-20 implements 8 outputs.

The 16 (8) digital outputs are galvanically isolated by optocoupler. They are isolated against each other in groups of two. Each group can be individually configured as high or low side switch. The output drivers are capable of driving 0.5 A continuous per channel. They resist short-circuits and are protected against thermal overload.

The implemented hardware watchdog can be activated for automatic deactivation of the outputs in case of a software failure.

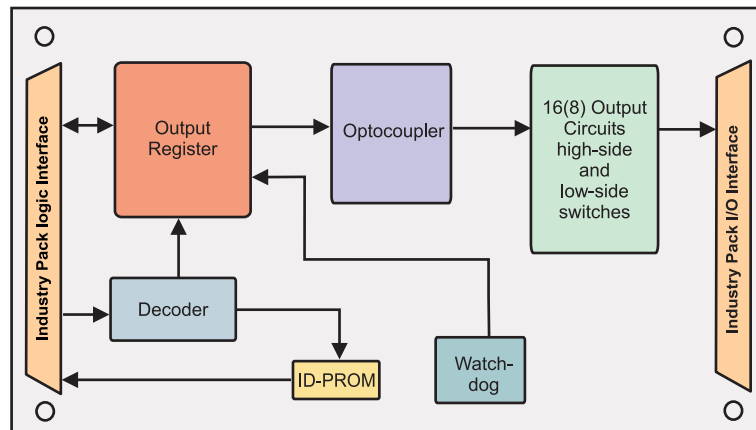

Figure 1-1 : Block Diagram

## 2 Technical Specification

<b>Logic Interface</b>	IndustryPack® Logic Interface
<b>Size</b>	Single size IP
<b>I/O Interface</b>	50-conductor flat cable
<b>Number of Outputs</b>	TIP700-10: 16 TIP700-20: 8
<b>Output Isolation</b>	All channels, each two channels share the same power supply and ground
<b>External Supply Voltage for Outputs</b>	24V DC typical 6V DC minimum 48V DC maximum
<b>Output Current</b>	0.5A maximum (0.4A for voltages over 32V)
<b>Short Circuit Current</b>	0.8A typical ( 2A maximum)
<b>Output Voltage Drop</b>	1.1V typical at 0.5A
<b>Output Protection</b>	Overload, short circuit, GND and Vs open wire protection, thermal shutdown
<b>Output Watchdog</b>	can be enabled under software control, 120 msec time out
<b>Wait States</b>	IDPROM: no wait states I/O: no wait states
<b>Power Requirements</b>	65 mA typical @+5V for all outputs disabled 125 mA typical@+5V for all outputs enabled
<b>Temperature Range</b>	Operating -25°C to +85°C Storage -55°C to +125°C
<b>Humidity</b>	5 - 95% non-condensing
<b>MTBF</b>	TIP700-10 : 286000 h TIP700-20 : 356000 h
<b>Weight</b>	26 g
<b>Transition Module</b>	Optional (TIP001-TM-10)

Table 2-1 : Technical Specification

### 3 ID Prom Contents

Address	Function	Contents
0x01	ASCII 'I'	0x49
0x03	ASCII 'P'	0x50
0x05	ASCII 'A'	0x41
0x07	ASCII 'C'	0x43
0x09	Manufacturer ID	0xB3
0x0B	Model Number	0x05
0x0D	Revision	0x10
0x0F	Reserved	0x00
0x11	Driver-ID Low - Byte	0x00
0x13	Driver-ID High - Byte	0x00
0x15	Number of bytes used	0x0C
0x17	CRC	0xD7

Table 3-1 : ID PROM contents TIP700-10

Address	Function	Contents
0x01	ASCII 'I'	0x49
0x03	ASCII 'P'	0x50
0x05	ASCII 'A'	0x41
0x07	ASCII 'C'	0x43
0x09	Manufacturer ID	0xB3
0x0B	Model Number	0x06
0x0D	Revision	0x10
0x0F	Reserved	0x00
0x11	Driver-ID Low - Byte	0x00
0x13	Driver-ID High - Byte	0x00
0x15	Number of bytes used	0x0C
0x17	CRC	0x55

Table 3-2 : ID PROM contents TIP700-20



## 4 IP Addressing

The TIP700 is accessed in the I/O space through the following set of two direct accessible registers:

Address	Symbol	Description	Size (Bit)	Access
0x00	OUTPUT	Output Data Register	word	R/W
0x02	WDGCSR	Watchdog Control Register	word	W

Table 4-1 : Register Map

## **5 Functional Description**

### **5.1 Digital Outputs**

#### **5.1.1 Optical Isolation**

The TIP700 has 16 (TIP700-10) or 8 (TIP700-20) digital outputs. The standard signal level for these outputs is 24V DC. All output channels are isolated by optocoupler and are isolated against each other in groups of two outputs.

#### **5.1.2 Output Polarity**

Each output can be individually configured as a high or a low side switch depending on the external wiring of the output signal lines.

#### **5.1.3 Overload Protection**

The output drivers are implemented by smart drivers TDE1707. The maximum continuous output current is 0.5 A. The output circuits are protected against overload, short circuit and thermal overload. In case of such failure the corresponding output will be disabled until the error condition is removed. Then the output returns automatically to normal operation.

#### **5.1.4 Output Watchdog**

The TIP700 IP has an output watchdog which can be enabled under software control. When the watchdog is active a mono stable flip-flop is retriggered with each write to the output data register OUTDAT. If there is no write access within approximately 120msec, the watchdog resets all outputs.

**The watchdog is disabled after power-up or reset.**

# 6 Programming

## 6.1 Output Data Register OUTDAT (Base Address +0x00)

The status of the outputs can be manipulated directly by writing to the Output Data Register OUTDAT. Each bit of this data register is controlling one output line. TIP700-20 only use 8 outputs (bit 7:0)

Bit	Symbol	Description	Access	Reset Value
15	OUTPUT 16	To set an output channel active, write a '1' to the corresponding bit. For the inactive state write a '0' to the corresponding bit.  0 : inactive 1 : active	R/W	0
14	OUTPUT 15			
13	OUTPUT 14			
12	OUTPUT 13			
11	OUTPUT 12			
10	OUTPUT 11			
9	OUTPUT 10			
8	OUTPUT 9			
7	OUTPUT 8	Bit manipulating instructions can be used to modify the status of single outputs.	R/W	0
6	OUTPUT 7			
5	OUTPUT 6			
4	OUTPUT 5			
3	OUTPUT 4			
2	OUTPUT 3			
1	OUTPUT 2			
0	OUTPUT 1			

Table 6-1 : Output Data Register OUTDAT

**After a system reset all outputs are inactive.**

## 6.2 Watch Dog Control Register (Base Address 0x02)

The output watchdog is controlled by the Watchdog Control Register WDGCSR.

Bit	Symbol	Description	Access	Reset Value
15:1		Unused bits, access don't care		
0	Watchdog Enable	Watchdog Control 1 = enabled	W	0

Table 6-2 : Watch Dog Control Register WDGCSR

**The watchdog is disabled after power-up or reset.**

# 7 Installation

The outputs are optically isolated from the logic circuit in groups of two. Output channels 1 and 2, 3 and 4, 5 and 6, 7 and 8, 9 and 10, 11 and 12, 13 and 14, 15 and 16 share the same output potential but are completely isolated against the other output groups. Each output can be individually be configured as a high side or a low side switch by corresponding wiring.

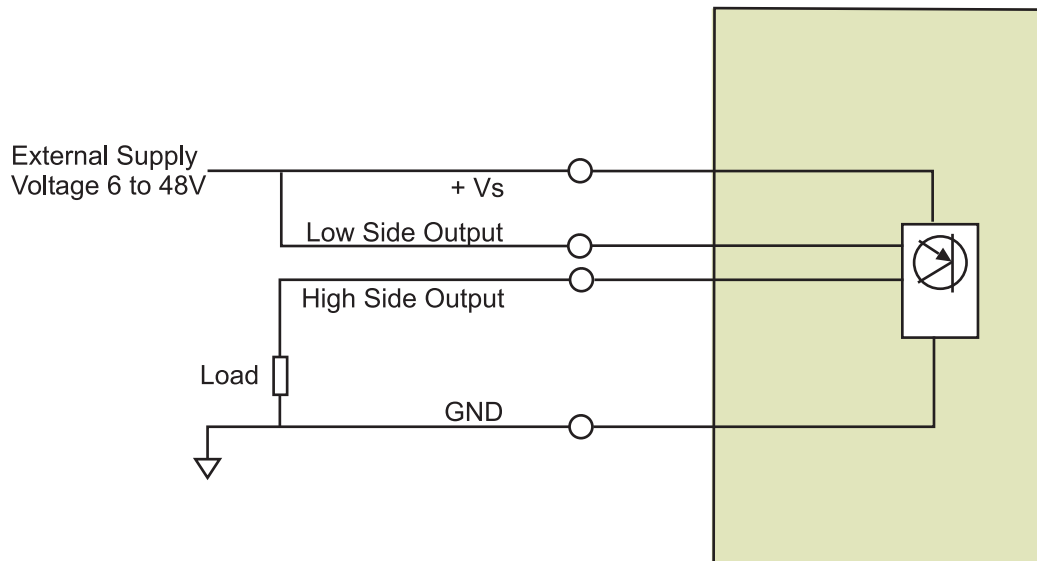

Figure 7-1 : Output Wiring as High Side Switch

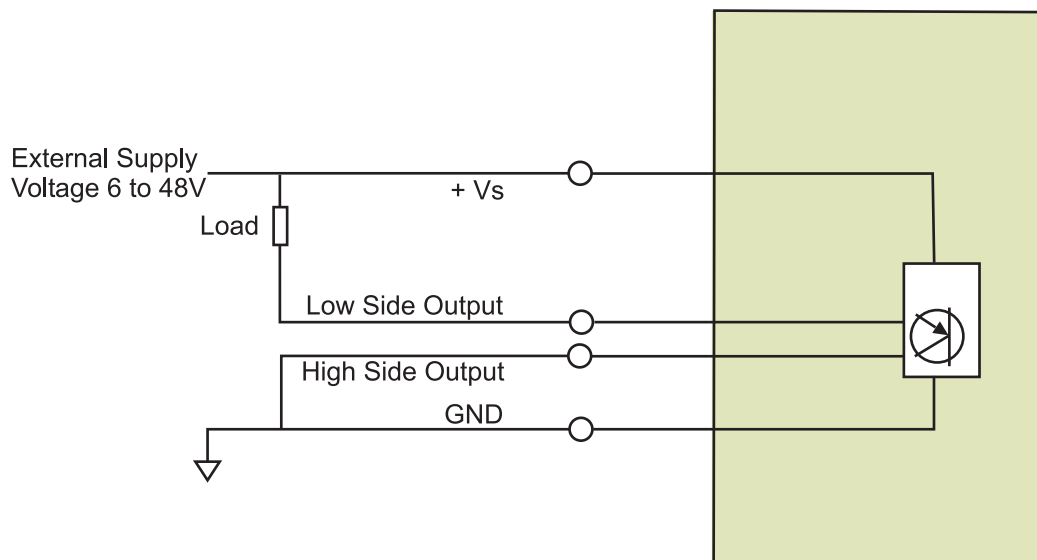

Figure 7-2 : Output Wiring as Low Side Switch

## 8 IP I/O Connector

Pin	Function	Comment
1	GND 1-2	External GND for Output 1-2
2	GND 3-4	External GND for Output 3-4
3	GND 5-6	External GND for Output 5-6
4	GND 7-8	External GND for Output 7-8
5	Low Side Output 1	
6	High Side Output 1	
7	Low Side Output 2	
8	High Side Output 2	
9	Low Side Output 3	
10	High Side Output 3	
11	Low Side Output 4	
12	High Side Output 4	
13	Low Side Output 5	
14	High Side Output 5	
15	Low Side Output 6	
16	High Side Output 6	
17	Low Side Output 7	
18	High Side Output 7	
19	Low Side Output 8	
20	High Side Output 8	
21	+VS 1-2	External Supply Voltage for Output 1-2
22	+VS 3-4	External Supply Voltage for Output 3-4
23	+VS 5-6	External Supply Voltage for Output 5-6
24	+VS 7-8	External Supply Voltage for Output 7-8
25	NC	

Table 8-1 : Output I/O connection output 1 to 8

Pin	Function	Comment
26	GND 9-10	External GND for Output 9-10
27	GND 11-12	External GND for Output 11-12
28	GND 13-14	External GND for Output 13-14
29	GND 15-16	External GND for Output 15-16
30	Low Side Output 9	
31	High Side Output 9	
32	Low Side Output 10	
33	High Side Output 10	
34	Low Side Output 11	
35	High Side Output 11	
36	Low Side Output 12	
37	High Side Output 12	
38	Low Side Output 13	
39	High Side Output 13	
40	Low Side Output 14	
41	High Side Output 14	
42	Low Side Output 15	
43	High Side Output 15	
44	Low Side Output 16	
45	High Side Output 16	
46	+VS 9-10	External Supply Voltage for Output 9-10
47	+VS 11-12	External Supply Voltage for Output 11-12
48	+VS 13-14	External Supply Voltage for Output 13-14
49	+VS 15-16	External Supply Voltage for Output 15-16
50	NC	

Table 8-2 : Output I/O connection output 9 to 16 (TIP700-10 only)